

# Fashion Bed Group

A Division of Leggett & Platt Incorporated

## Parts List For Astoria Daybed

### PART #361701 HARDWARE BAG FOR DAYBED

- (1) 1/4-20 2 3/4" ALLEN HEAD SCREW-4
- (2) 1/4-20 3/4" ALLEN HEAD SCREW-8
- (3) 5/8" OD METAL WASHER-12
- (4) ALLEN WRENCH-1

#### DAYBED PARTS:

- (5) RIGHT SIDE-1
- (6) LEFT SIDE-1
- (7) BACK PANEL-1

#### LINK SPRING PARTS:

- (8) LEFT BRACKET-2
- (9) RIGHT BRACKET-2
- (10) 5/16-18 SCREW-4
- (11) 5/16-18 HEX NUT-4
- (12) SUPPORT DECK-1

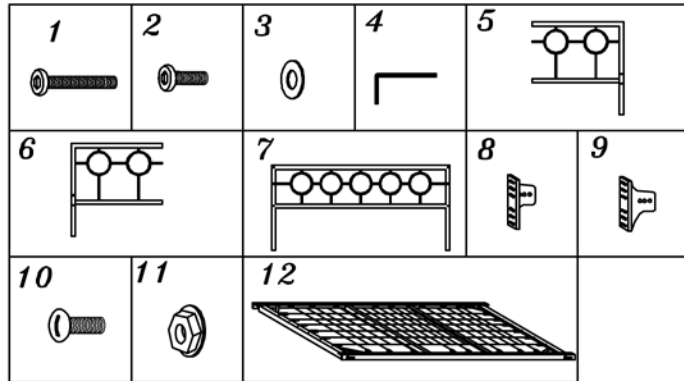

SAVE ALL PACKAGING MATERIALS UNTIL PRODUCT IS FULLY ASSEMBLED. HARDWARE AND SMALL PIECES MAY NOT BE SEEN AND BE ACCIDENTALLY DISCARDED WITH PACKAGING MATERIALS.

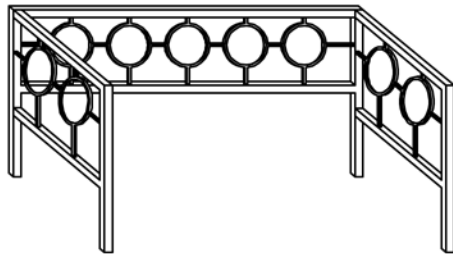

MATTRESS LINK SPRING FULLY ASSEMBLED

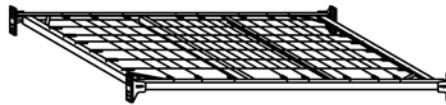

OPTIONAL

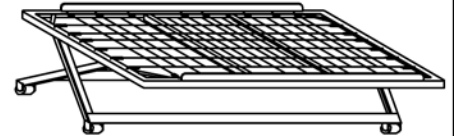

POP-UP TRUNDLE

## DAYBED FULLY ASSEMBLED

### Instruction Sheet

**NOTE:** For ease of assembly you will need a helper.  
 • Periodically retighten all screws.

### Step 1- Locate Hardware bags for Daybed & Link Spring Assembly

- Hardware bag for assembly Daybed is located inside the daybed carton box.
- Link spring hardware bag is located below the link spring cross bar.

### Step 2- Link Spring Assembly

- Attach left & right brackets (9 & 10) to side rails using screws (11) and nuts (12).

See Figure 1

FIGURE 1

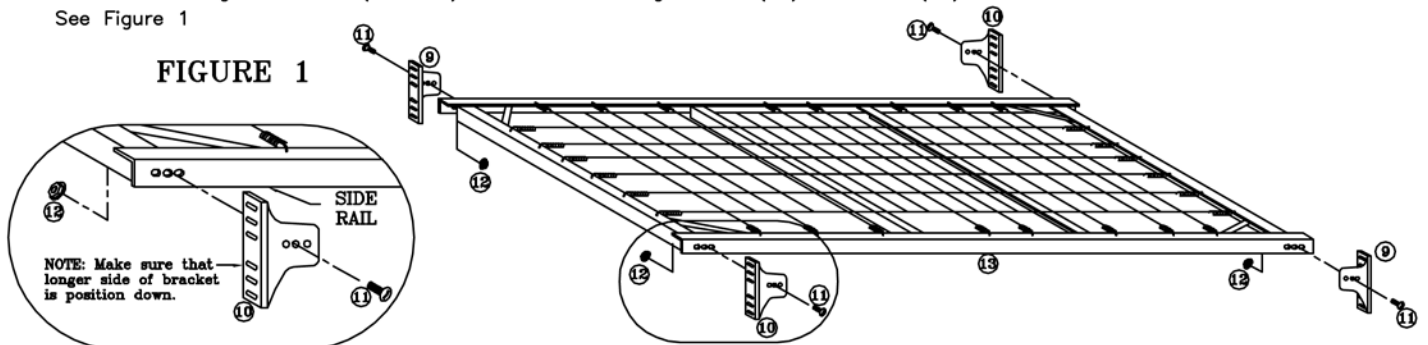

# Instruction Sheet

## Step 2- Attachment of Back panel to Daybed sides

- Align holes in back panel (7) with end rails of left side (6). See Figure 2
- Secure back panel and left side with screws (1) and washers (3). Tighten screws with Allen wrench (4). See Figure 2
- Repeat on other daybed posts.

FIGURE 2

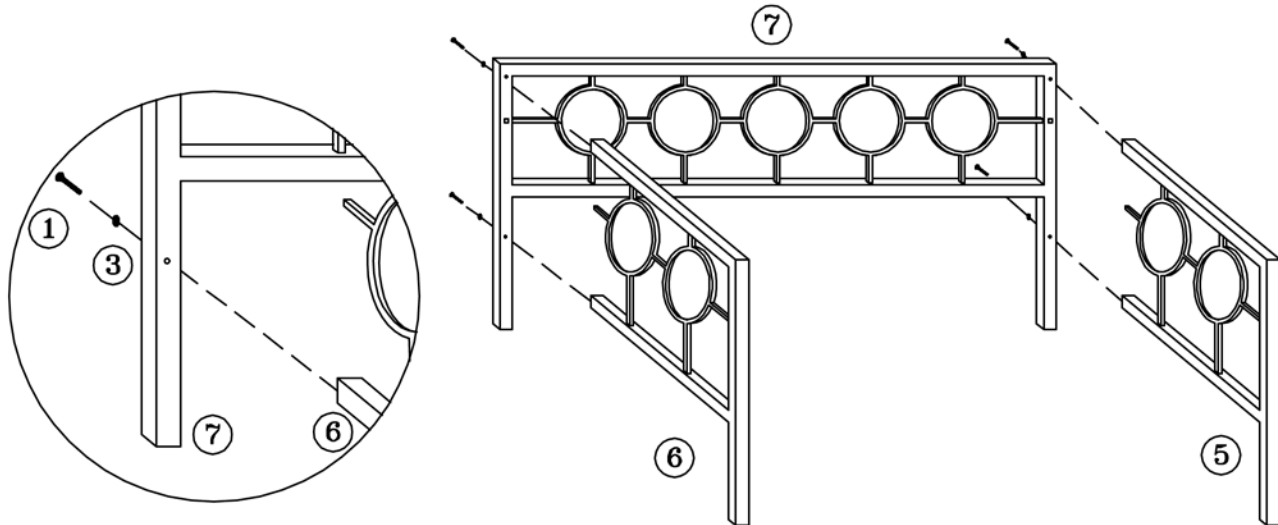

## Step 3- Attachment of Link Spring to Daybed sides

- Bolt one metal bracket of the link spring to one daybed side post.
- For each post use 2 screws (2), and 2 metal washers (3). Loosely tighten. See Figure 3
- Repeat on other daybed posts.
- Tighten screws with Allen wrench (4). See Figure 2

FIGURE 3

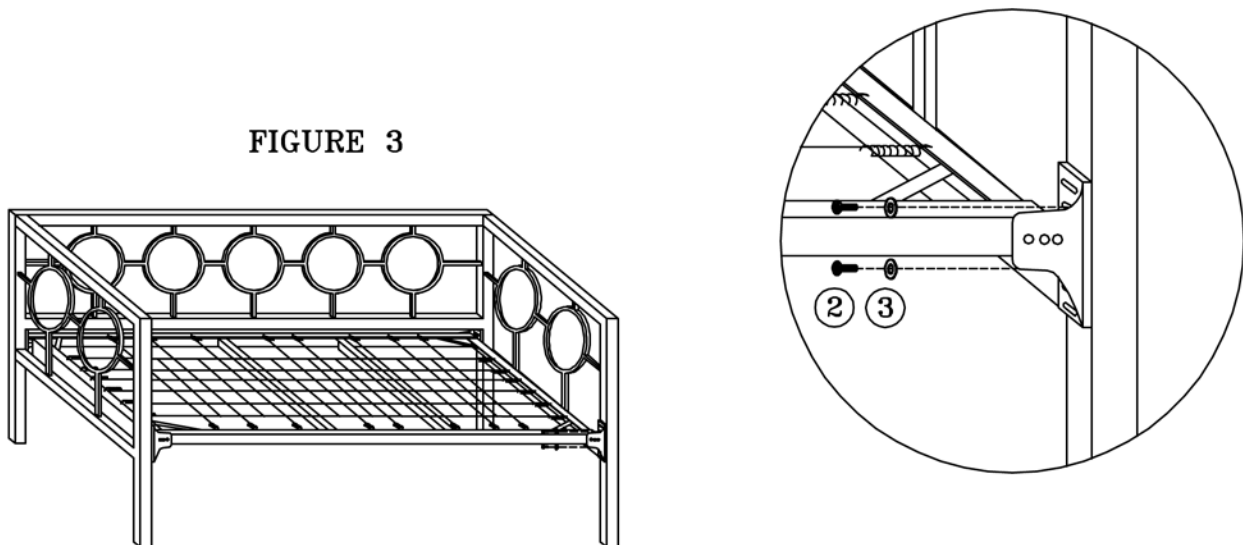

# Instruction Sheet

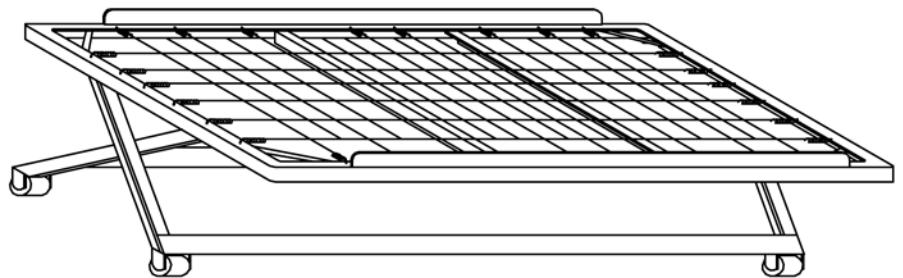
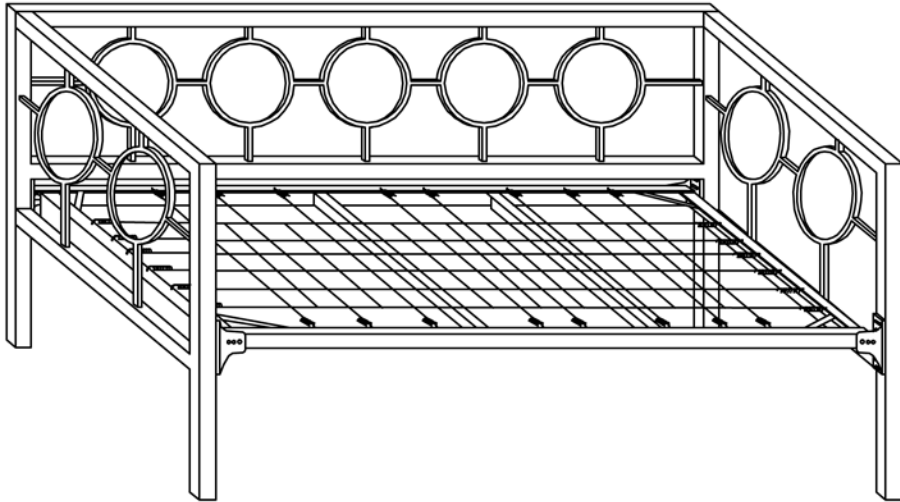

OPTIONAL

FIGURE 4